

COLOR: \_\_\_\_\_  
 HANDRAIL WOOD SPECIES: \_\_\_\_\_  
 HANDRAIL WOOD FINISH: \_\_\_\_\_  
 COLOR TO BE SELECTED FROM ONE OF C/S STANDARD COLORS.

TOTAL L/F REQ'D	LEFT END CAPS	RIGHT END CAPS

**NOTES:**

1. THIS MODEL IS FABRICATED CUT-TO-SIZE, THEREFORE FIELD VERIFIED DIMENSIONS ARE REQUIRED.

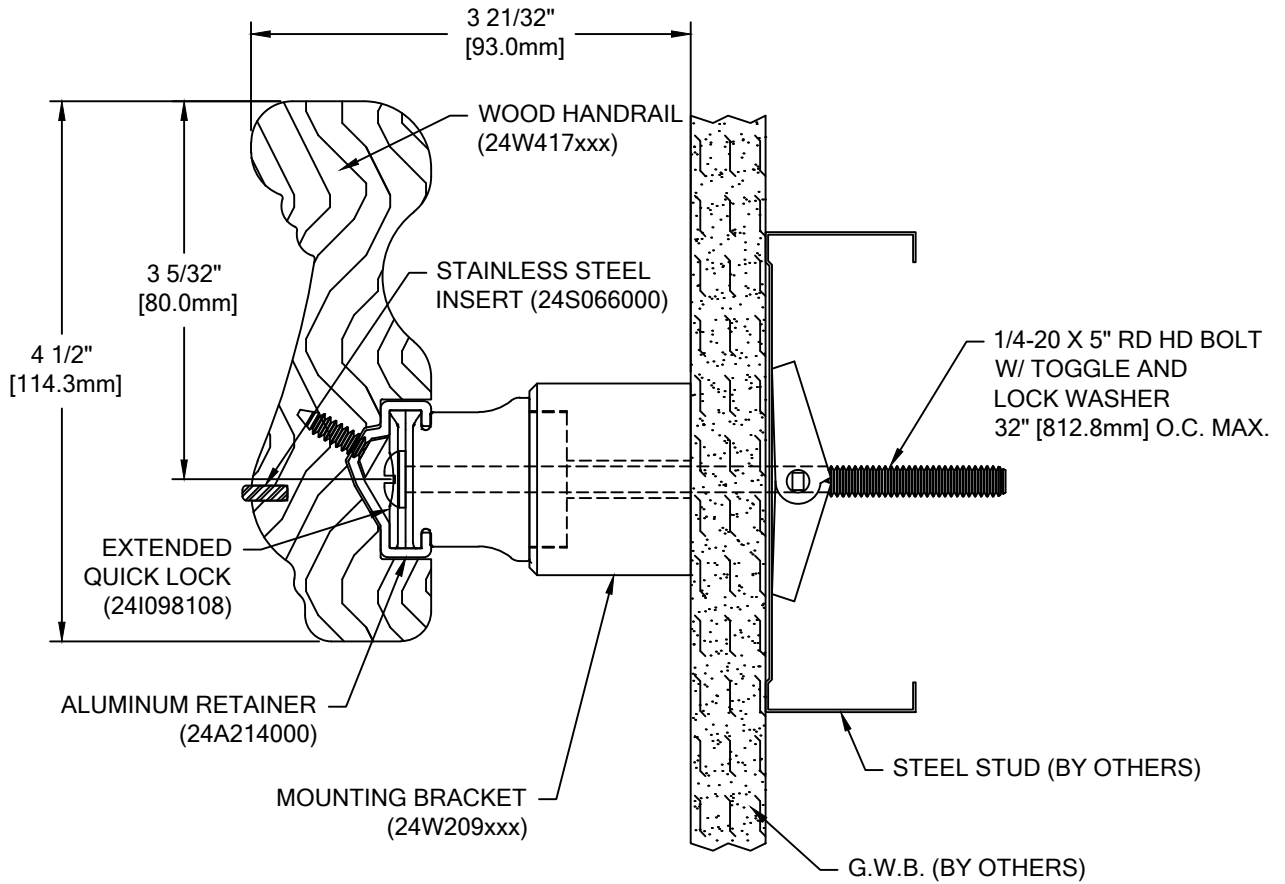

## HRW-45S

### INTERNATIONAL OFFSET

WALL CONDITION	SPECIFIED FASTENER	DRILL DIAMETERS		C/S PART NUMBER
		WALL	RETAINER	
STEEL STUD/GYPSUM WALL	1/4-20 X 5\"/>			
CONCRETE/CONCRETE BLOCK	#14 X 5\"/>			
WOOD STUD/GYPSUM WALL	#14 X 5\"/>			

 <p><b>Construction Specialties™</b>          6696 Route 405 Highway, Muncy PA 17756          (800) 233-8493 • Fax (570) 546-4692 • www.c-sgroup.com</p>	<b>PROJECT:</b>	<b>REVISION:</b>
	<b>JOB NO.:</b>	<b>F&amp;F:</b>
	<b>CUSTOMER:</b>	
	<b>REP:</b>	<b>DATE:</b>
	<b>DRAWN BY:</b>	<b>SHEET NO:</b>