

COLOR:
CRASH RAIL WOOD SPECIES: _____
CRASH RAIL WOOD FINISH: _____
***END CAPS:** _____
 COLOR TO BE SELECTED FROM ONE OF C/S STANDARD COLORS.
 *END CAPS AND STAINLESS STEEL COVERS ARE AVAILABLE WITH AN OPTIONAL POWDER COAT FINISH. PLEASE ADVISE POWDER COAT FINISH IF REQUIRED.
 WOOD END CAPS ALSO AVAILABLE.

TOTAL L/F REQ'D	END CAPS

NOTES:

1. THIS MODEL IS FABRICATED CUT-TO-SIZE, THEREFORE FIELD VERIFIED DIMENSIONS ARE REQUIRED.

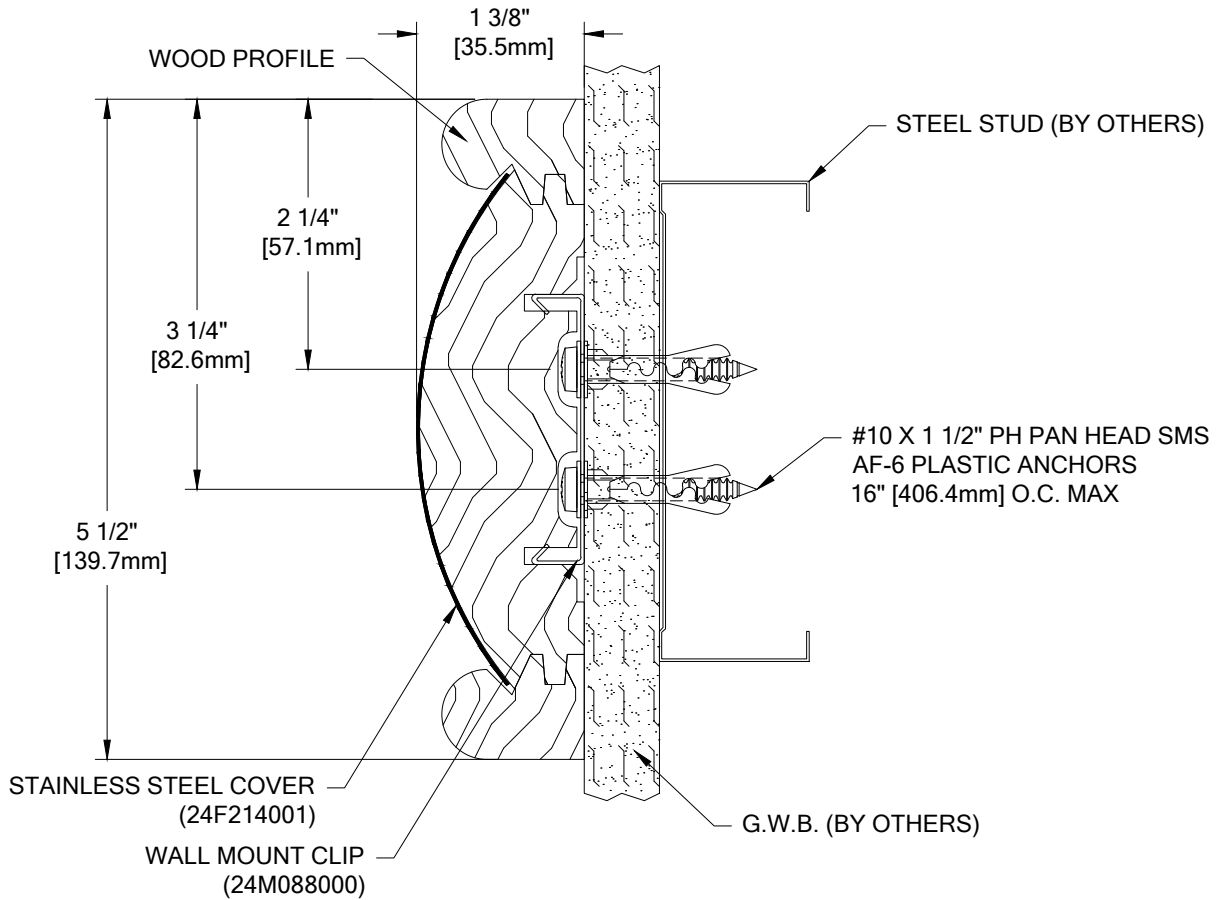

CRWS-3

WALL CONDITION	SPECIFIED FASTENER	DRILL DIAMETERS		C/S PART NUMBER
		WALL	RETAINER	
CONCRETE/CONCRETE BLOCK	#10 X 1 1/2" PHILLIPS PAN HEAD SMS AF-6 PLASTIC ANCHORS	1/4"	N/A	90H189002 90H039004
STEEL STUD/GYPSUM WALL	#10 X 1 1/2" PHILLIPS PAN HEAD SMS AF-6 PLASTIC ANCHORS	1/4"	N/A	90H189002 90H039004
WOOD STUD/GYPSUM WALL	#9 X 2 1/4" WAFER HD PH DRYWALL SCREW	N/A	N/A	90H421002

 Construction Specialties™ 6696 Route 405 Highway, Muncy PA 17756 (800) 233-8493 • Fax (570) 546-4692 • www.c-sgroup.com	PROJECT:	REVISION:
	JOB NO.:	F&F:
	CUSTOMER:	
	REP:	DATE:
	DRAWN BY:	SHEET NO: