

MODEL GTP/GTR-200 THRU 400 & GTPW/GTRW-200 THRU 400 INSTALLATION INSTRUCTIONS

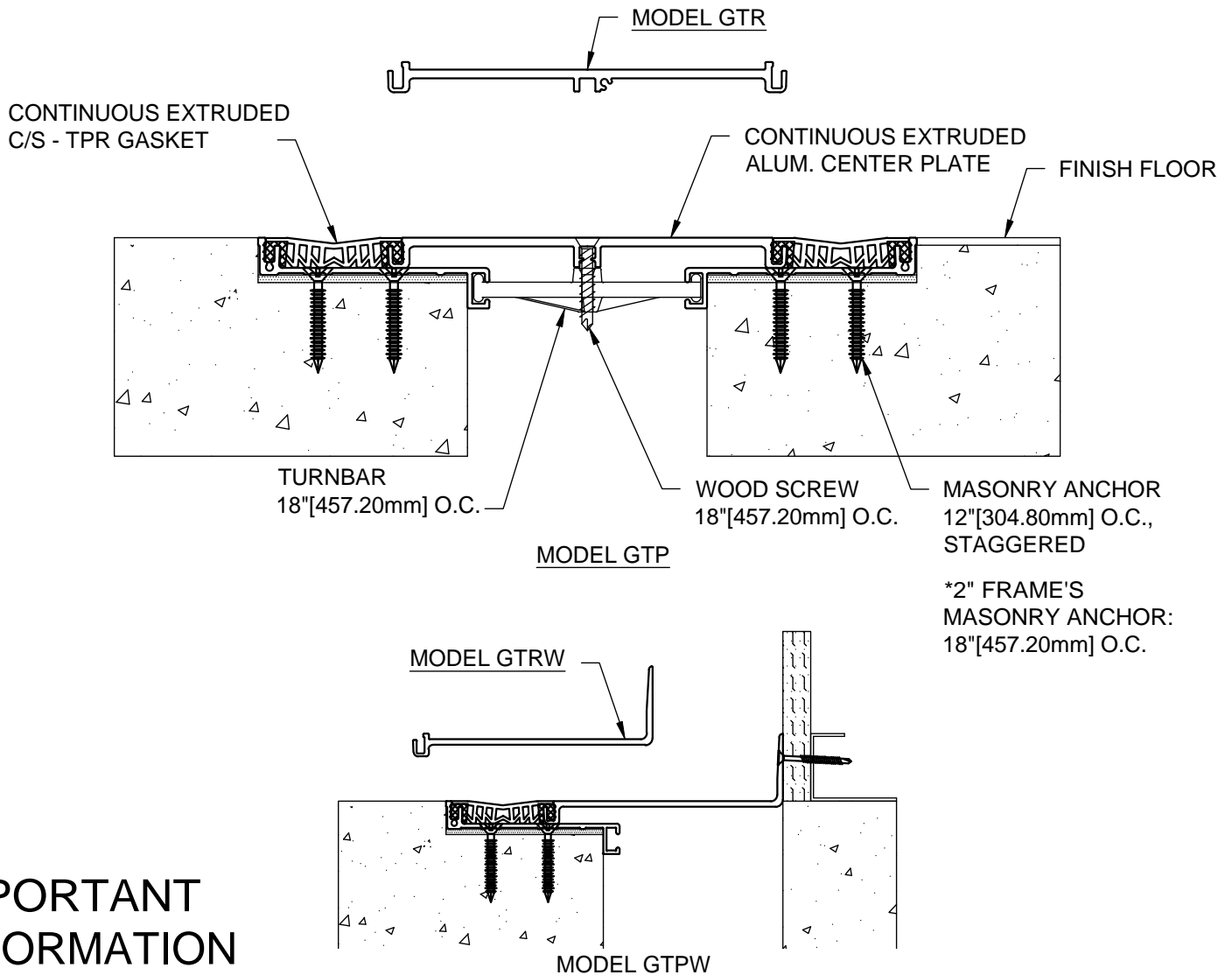

IMPORTANT INFORMATION

Prior to the commencement of installation, all materials **MUST** be inspected for damage. Any damage must be reported to CONSTRUCTION SPECIALTIES, INC., as soon as possible, so that replacement materials may be furnished without delay.

All work must be completed as per Architect's Approved "Shop Drawings", and in accordance with these Installation Instructions. When installation is complete, all materials must be protected from damage until the Architect's FINAL INSPECTION.

IMPORTANT:

READ THROUGH ALL INSTRUCTIONS PRIOR TO STARTING INSTALLATION

11/3/10



Construction Specialties™

6696 Route 405 Highway, Muncy PA 17756
(800) 233-8493, Fax (570) 546-5169, www.c-sgroup.com

This document is the property of Construction Specialties, Inc. and contains CONFIDENTIAL PROPRIETARY INFORMATION that is not to be disclosed to third parties and is not to be used without approval in writing from Construction Specialties, Inc.

Notes

Before beginning installation, review the architectural drawings and approved Construction Specialties Inc. shop drawings to familiarize yourself with the joint cover models and locations.

Check all of the joint cover components to confirm that the correct joint cover model and size have been received. Also, check for materials that may have been damaged during shipping. Report all incorrect and/or damaged components to C/S at 800-233-8493.

Read through all the steps of these instructions prior to beginning work.

STEP 1

PREPARE BLOCKOUT

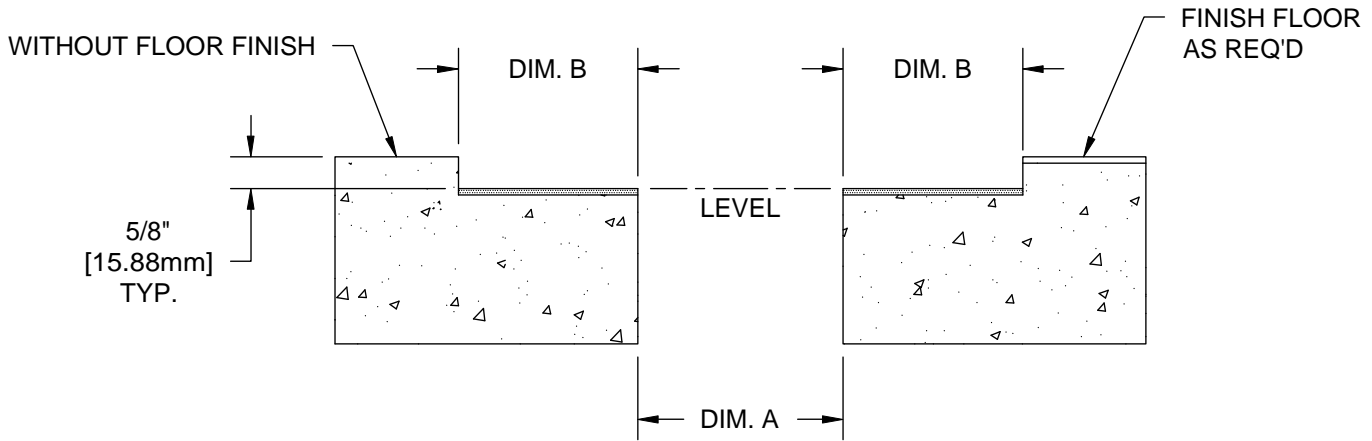

BLOCKOUT DIMENSIONS	
DIM. A	DIM. B
2" [50.80mm]	2 1/4" [57.15mm]
3" [76.20mm]	3 1/2" [88.90mm]
4" [101.60mm]	3 1/2" [88.90mm]

Step 1:

- 1.1) The blockouts must be prepared to receive the joint cover.
 - The blockout width (Dim. B) will vary with model as indicated above or as noted on the C/S shop drawings.
 - The blockout depth will typically be 5/8"[15.87mm]. However, the depth may be adjusted as needed to accommodate a floor finish material when required and as indicated on the architectural drawings and/or C/S shop drawings.
 - It is recommended that the blockouts be formed a minimum of 1/8" deeper to allow the blockouts to be leveled for installation of the joint cover.
 - Apply a high-strength non-latex leveling grout to the base of the blockouts to provide a continuous, solid, flat and level base for the joint cover. (Note: The blockouts must be level across the width of the joint.)

STEP 2

FRAME INSTALLATION

NOTE:
2" FRAME RECEIVES
SINGLE MASONRY
ANCHOR,
18" [457.20mm] O.C.

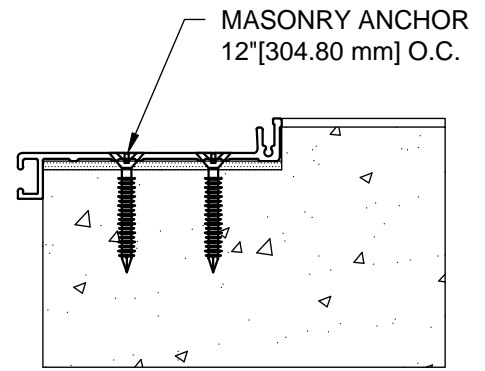
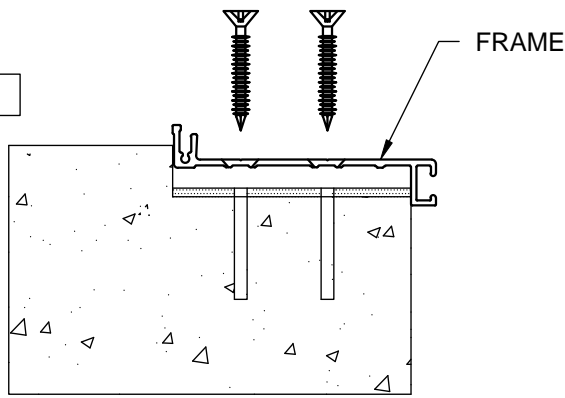
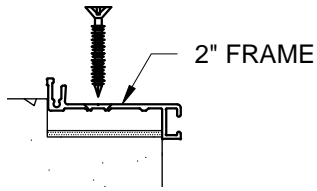

MODELS GTP/GTR

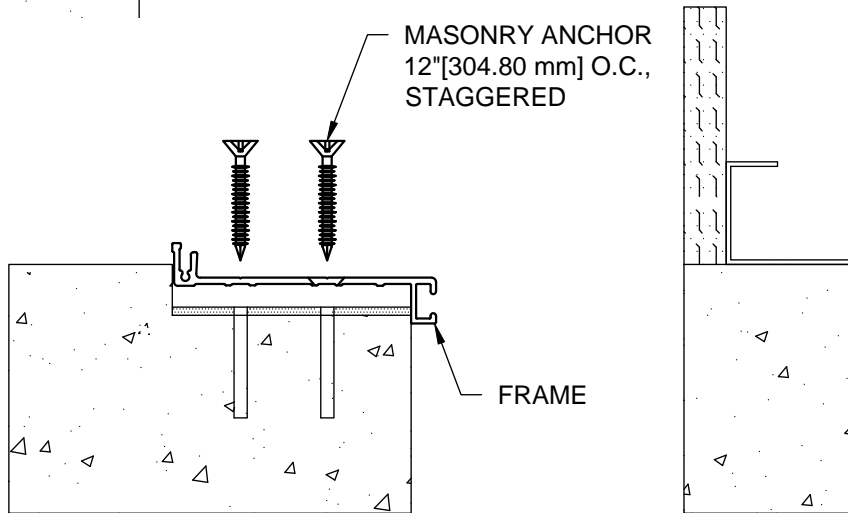

MODELS GTPW/GTRW

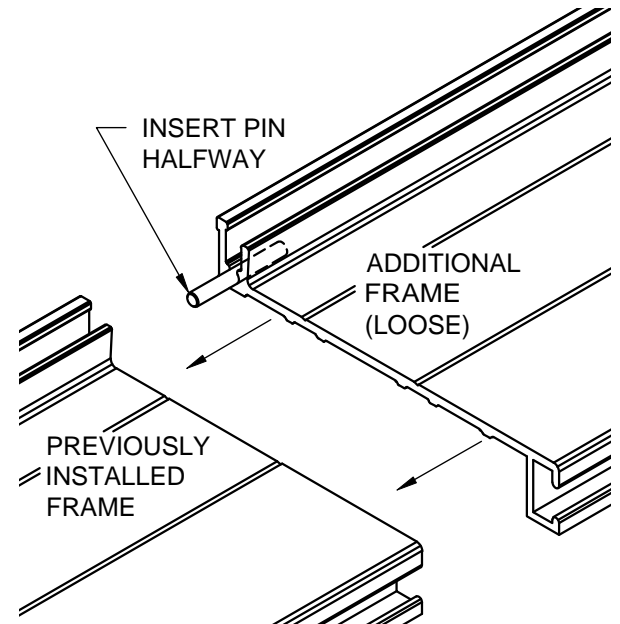

Note:

- If a C/S Fire Barrier is to be installed in the joint, please review the Fire Barrier Installation Instructions supplied, and if required install the Fire Barrier BEFORE installation of C/S Seismic Expansion Joint Aluminum Frames.
- If a Vapor Barrier/Waterstop is to be installed in the joint, please review the Vapor Barrier/Waterstop Installation Instructions supplied, and if required install the Vapor Barrier/Waterstop BEFORE installation of C/S Seismic Expansion Joint Aluminum Frames.
- If there is an expected temperature change of 20°F(+) daily, leave a 1/16" gap between Frames for 10' sections or an 1/8" gap between Frames for a 20' section due the thermal expansion of aluminum. Caulk (by others) in between Frames to seal gap.

Step 2:

- 2.1) Begin installation of the Frames by placing a length of Frame into the blockout. Cut the Frame to length as needed. The Frame is to sit level, flat and parallel to the edge of the joint.
- 2.2) Using the Frame as a template, drill holes for the C/S supplied anchor bolts per manufacturer's guidelines.
- 2.3) Anchor the Frame to the slab using the C/S supplied anchor bolts following the manufacturer's guidelines.
- 2.4) Repeat this installation procedure for opposite side of the joint and for any additional lengths of Frame.
- 2.5) For additional lengths of Frame, insert the Alignment Pin halfway into the alignment slots of the Additional Frame (loose) if necessary, apply a small amount of instant adhesive (by others) to secure the Pin.
- 2.6) Align the loose Frame with the previously installed Frame and slide together. Make sure the Alignment Pins slide into the slots of the previously installed Frame.

Note: Do not install last section of Frames until after Step 3.

STEP 3

TURNBAR INSTALLATION

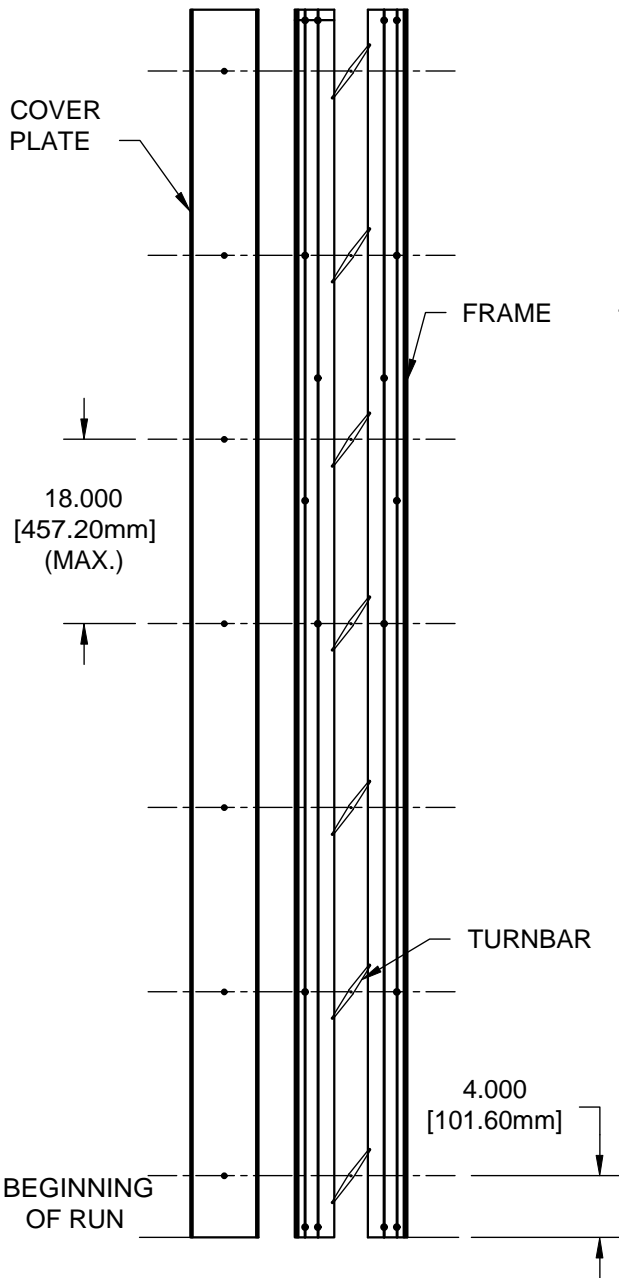

TURNBAR LOCATION

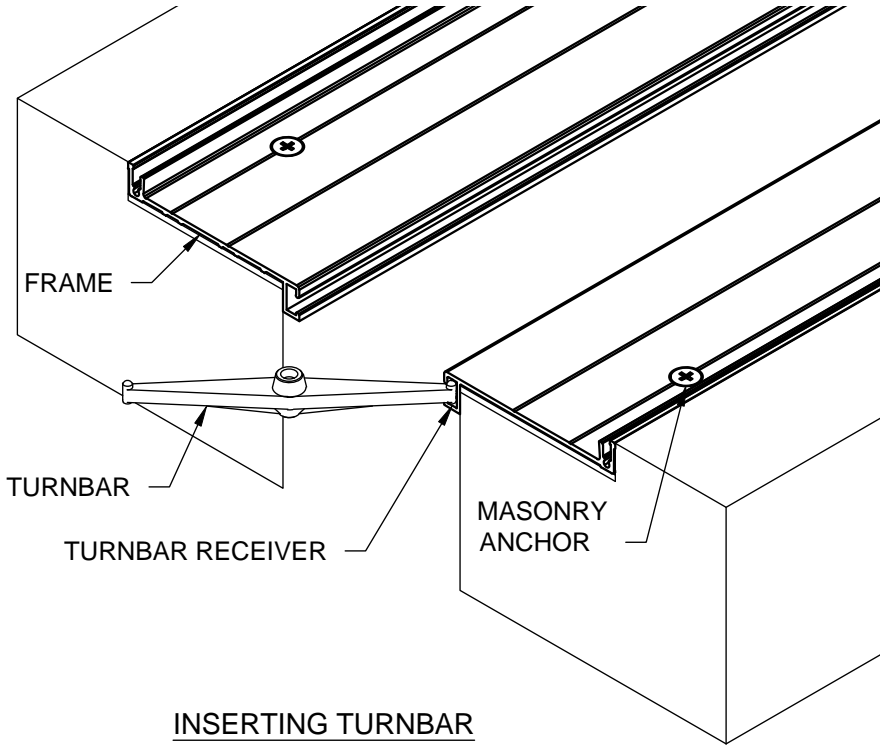

INSERTING TURNBAR

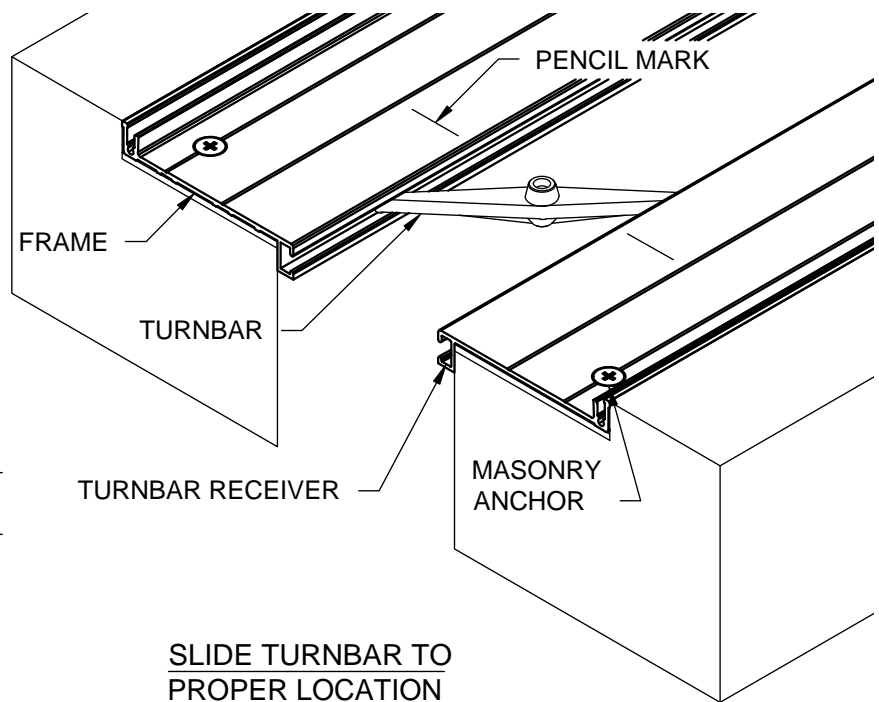

SLIDE TURNBAR TO PROPER LOCATION

Step 3:

- 3.1) Begin installation of the Turnbars by determining the number of Turnbars needed for the length of the run.
- 3.2) Determine the location of the Turnbars (see detail above) and mark the location on the Frames with a pencil.
- 3.3) Slide the Turnbars into the Turnbar receivers of the Frames (see detail above) and position the Turnbars to the marked locations.

Notes: The orientation of the Turnbars should all be the same direction or the system will not function. Please note the orientation of the Turnbars in the details above (the side with the part number on it faces up). Models GTPW & GTRW do not require any Turnbars.

STEP 4

END FRAME INSTALLATION

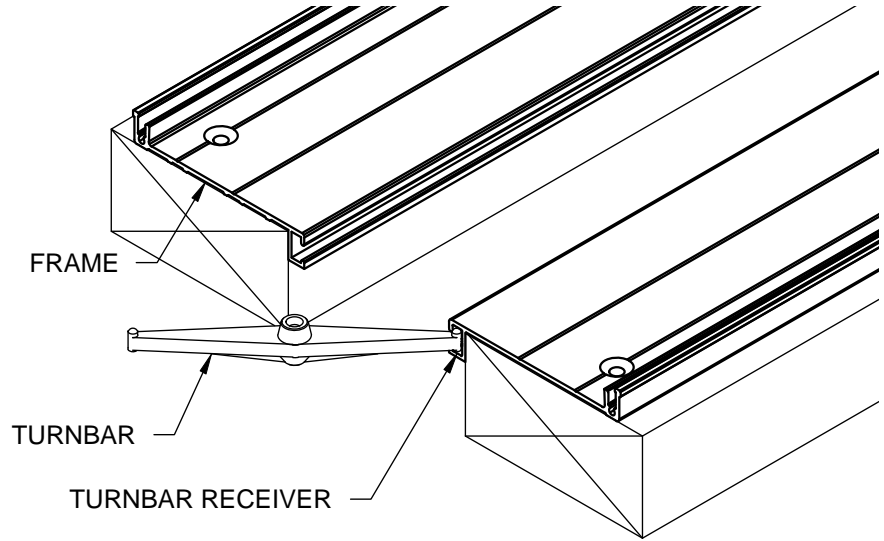
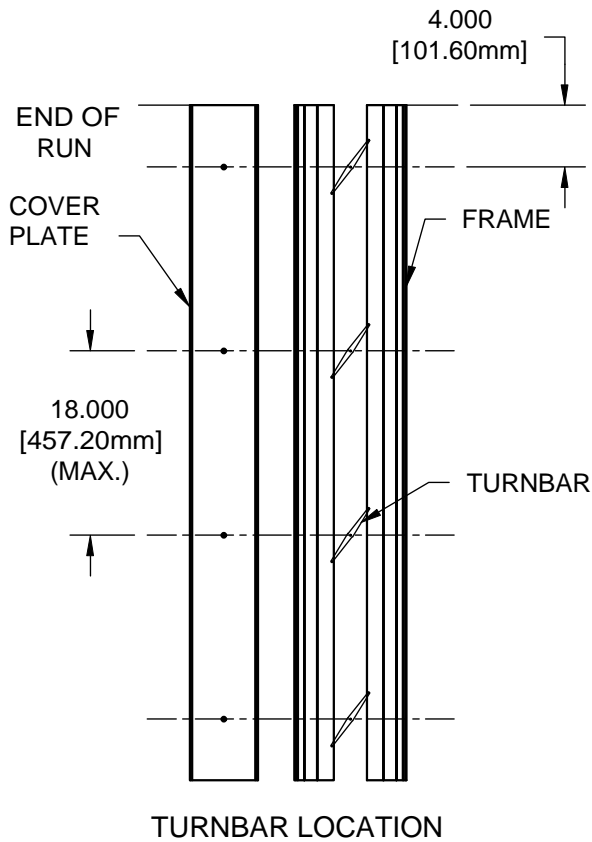

INSERTING TURNBARS

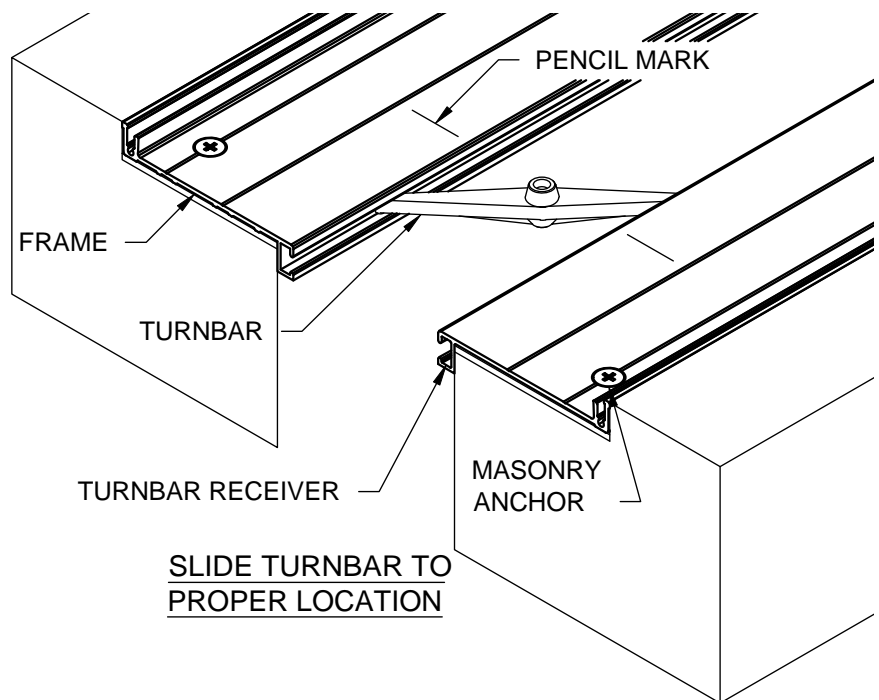

SLIDE TURNBAR TO PROPER LOCATION

Note:

- If there is an expected temperature change of 20°F(+) daily, leave a 1/16" gap between Frames for 10' sections or an 1/8" gap between Frames for a 20' section due the thermal expansion of aluminum. Caulk (by others) in between Frames to seal gap.

Step 4:

- 4.1) Begin installation of last section of Frame by cutting the Frame to length as needed. The Frame is to sit level, flat and parallel to the edge of the joint.
- 4.2) Lay Frame beside joint on wood blocking as shown in detail above.
- 4.3) Determine the number of Turnbars needed. Slide the Turnbars into the Turnbar receivers of the Frames (see detail above), position the Turnbars to proper locations and mark locations on Frames.
- 4.4) Place Frames with Turnbars into blockout. Using the Frames as a template, drill holes for the C/S supplied anchor per manufacturer's guidelines.
- 4.5) Anchor the Frame to the slab using the C/S supplied anchor bolts following the manufacturer's guidelines.
- 4.6) Reposition Turnbars to the marked locations.

Notes: The orientation of the Turnbars should all be the same direction or the system will not function. Please note the orientation of the Turnbars in the details above (the side with the part number on it faces up). Models GTPW & GTRW do not require any Turnbars.

STEP 5

CENTER PLATE INSTALLATION

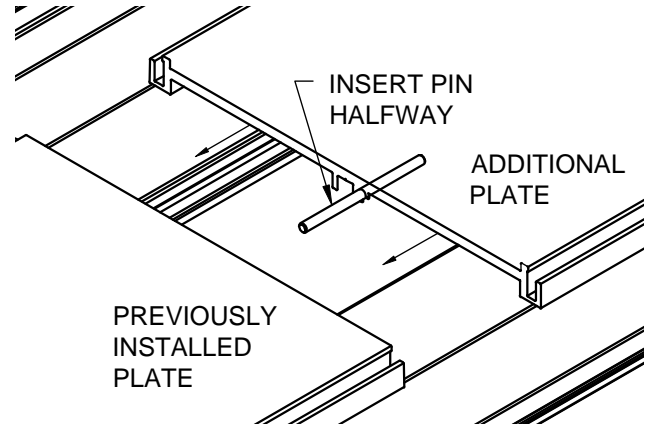
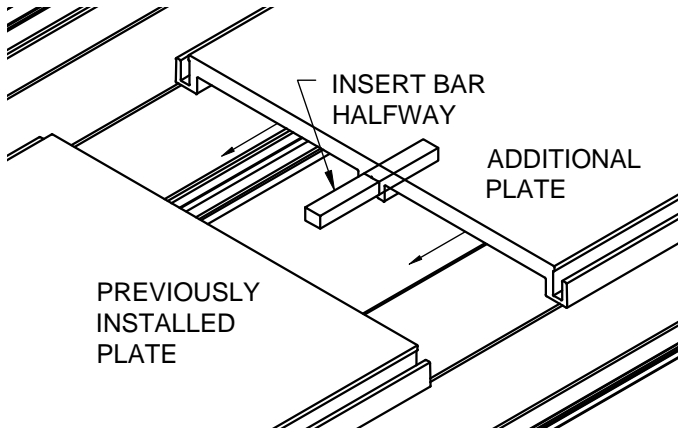
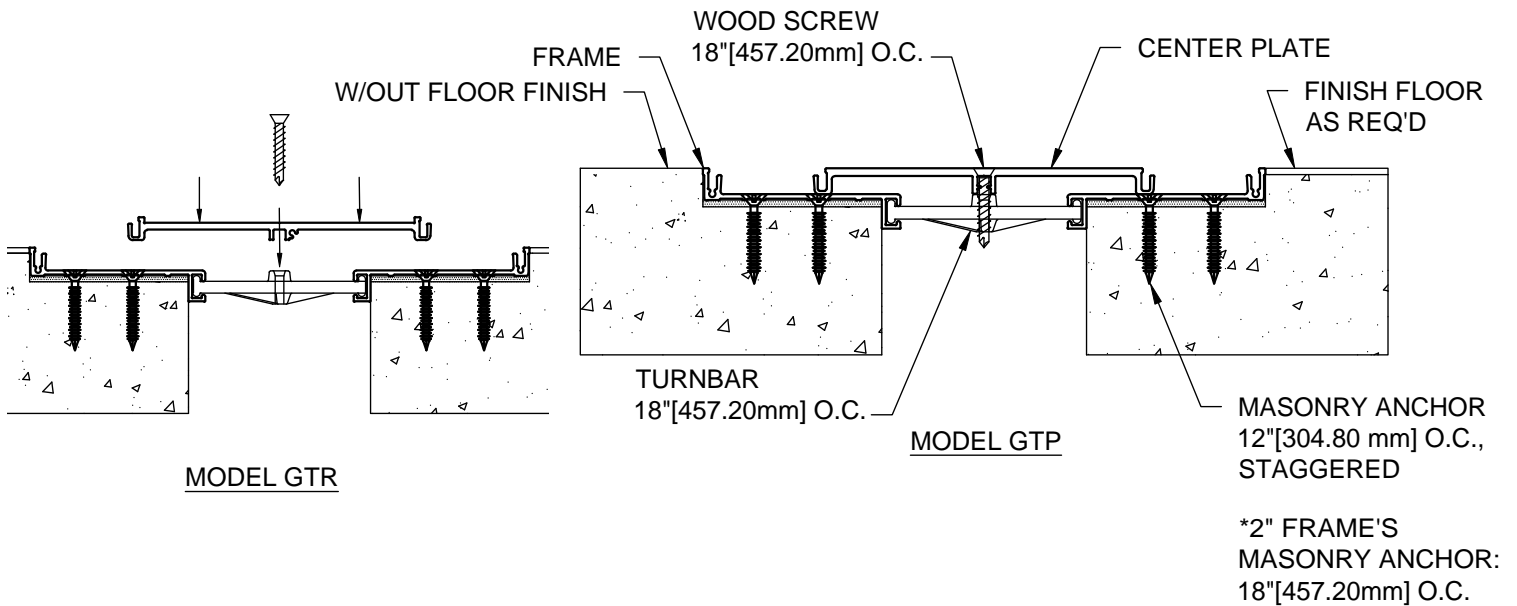

Note:
- If there is an expected temperature change of 20°F(+) daily, leave a 1/16" gap between Plates for 10' sections or an 1/8" gap between Plates for a 20' section due the thermal expansion of aluminum. Caulk (By Others) in between Plates to seal gap.

Step 5:

IMPORTANT NOTE: Over tightening of the Center Plates to the Turnbars will cause them to break. It is important to follow these instructions.

- 5.1) Begin installation of the Center Plate by first placing a length of the Center Plate beside the joint and cutting required length.
- 5.2) Center the Plate over the joint/Frames. Make sure that the holes of the Center Plate and Turnbars are aligned.

Note: You can do this by shining a light in the holes if necessary and using a wire to line up the holes.

- 5.3) Using the C/S supplied wood screws attach the Center Plate to the Turnbars. DO NOT FULLY TIGHTEN.
- 5.4) Once all of the wood screws have been partially fastened, go back through and tighten until the head of the screw is flush with the top of the Center Plate plus an additional 1/4 turn.
- 5.5) For additional lengths of Center Plate, insert the Alignment Bar or Pin halfway into the alignment slot of the previously installed Plate (see detail above). Apply a small amount of instant adhesive (by others) if necessary to secure the Alignment Bar or Pin.
- 5.6) Repeat Steps 5.1 through 5.4.

STEP 5

CENTER PLATE INSTALLATION

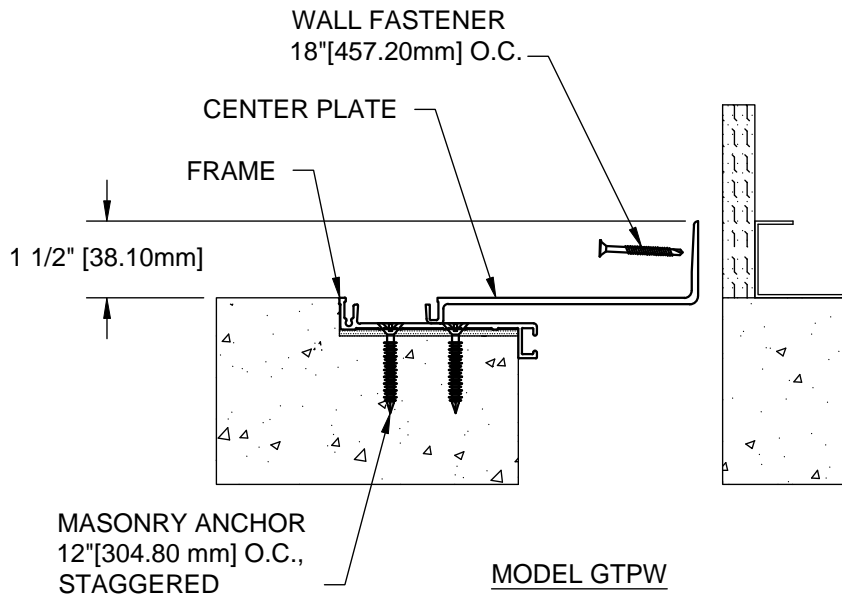

*2" FRAME'S
MASONRY ANCHOR:
18" [457.20mm] O.C.

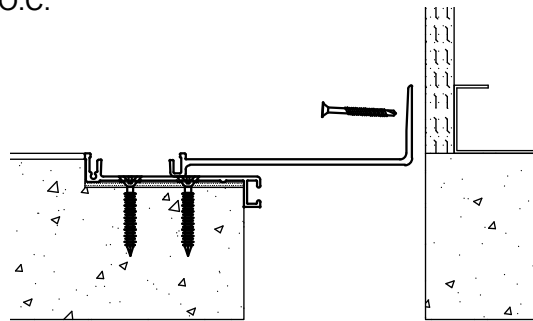

Note:

- If there is an expected temperature change of 20°F(+) daily, leave a 1/16" gap between Plates for 10' sections or an 1/8" gap between Plates for a 20' section due the thermal expansion of aluminum. Caulk (By Others) in between Plates to seal gap.

Step 5 Continued....:

Floor to Wall Applications:

5.6) Measure 1 1/2" [38.10mm] above slab surface and mark a line on the wall surface.

5.7) Align the top of the vertical flange of the Center Plate with the line.

5.8) Using the Center Plate as a template, mark and drill the location for the C/S supplied wall fasteners.

5.9) Attached the Center Plate using the C/S supplied wall fasteners in accordance with the manufacturer's guidelines.

5.10) Repeat these installation instructions for any additional lengths of Center Plate.

STEP 6

GASKET INSTALLATION

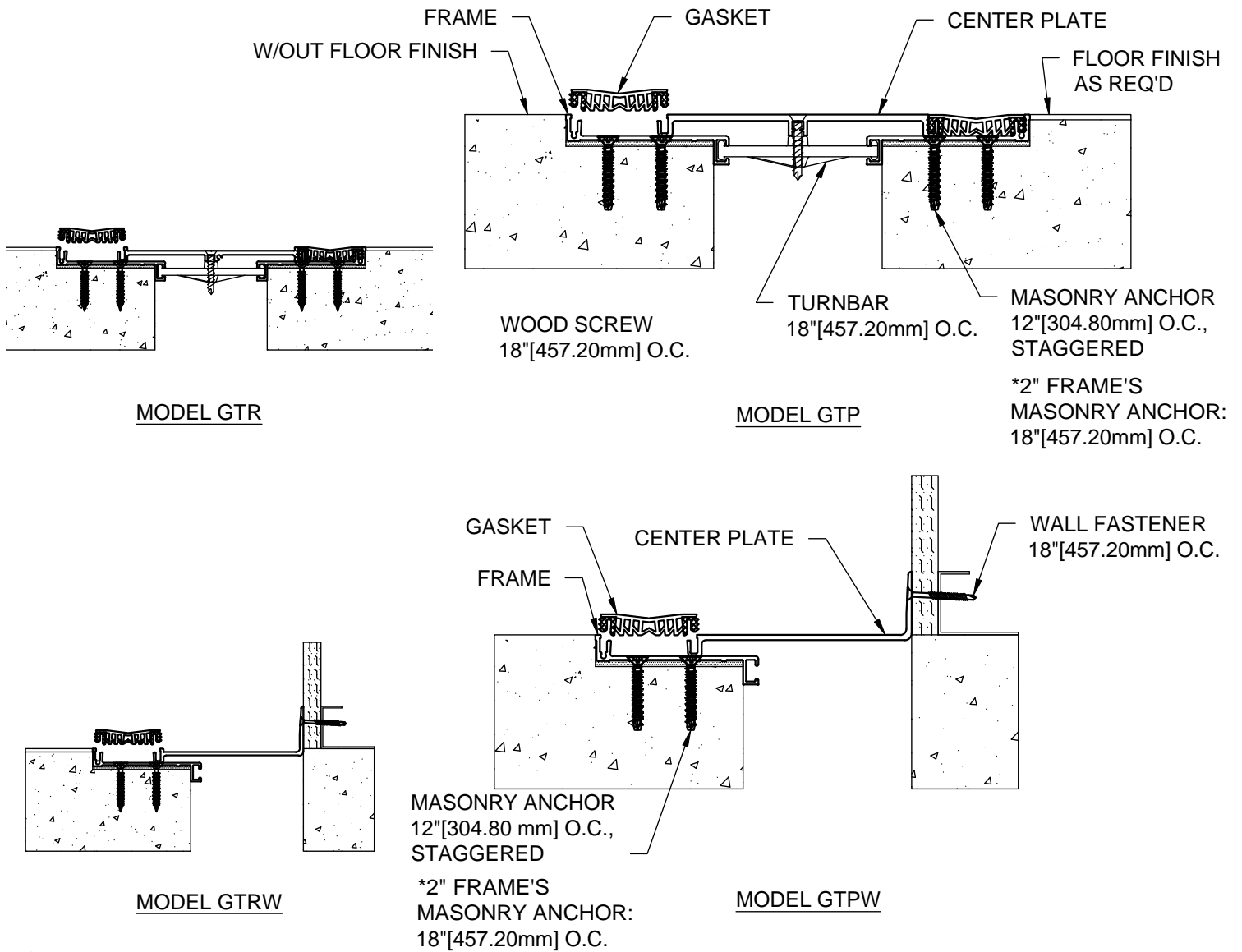

Step 6:

- 6.1) Complete the installation by inserting the Gaskets. It may be necessary to drive the Gasket in place using a rubber mallet and a wood block. Lubricating the push in areas by spraying them with a light mist of water will also ease the installation. When Gaskets are properly installed, they should be flush with the top surface of the Center Plate and Frames.

STEP 7

COMPLETE INSTALLATION

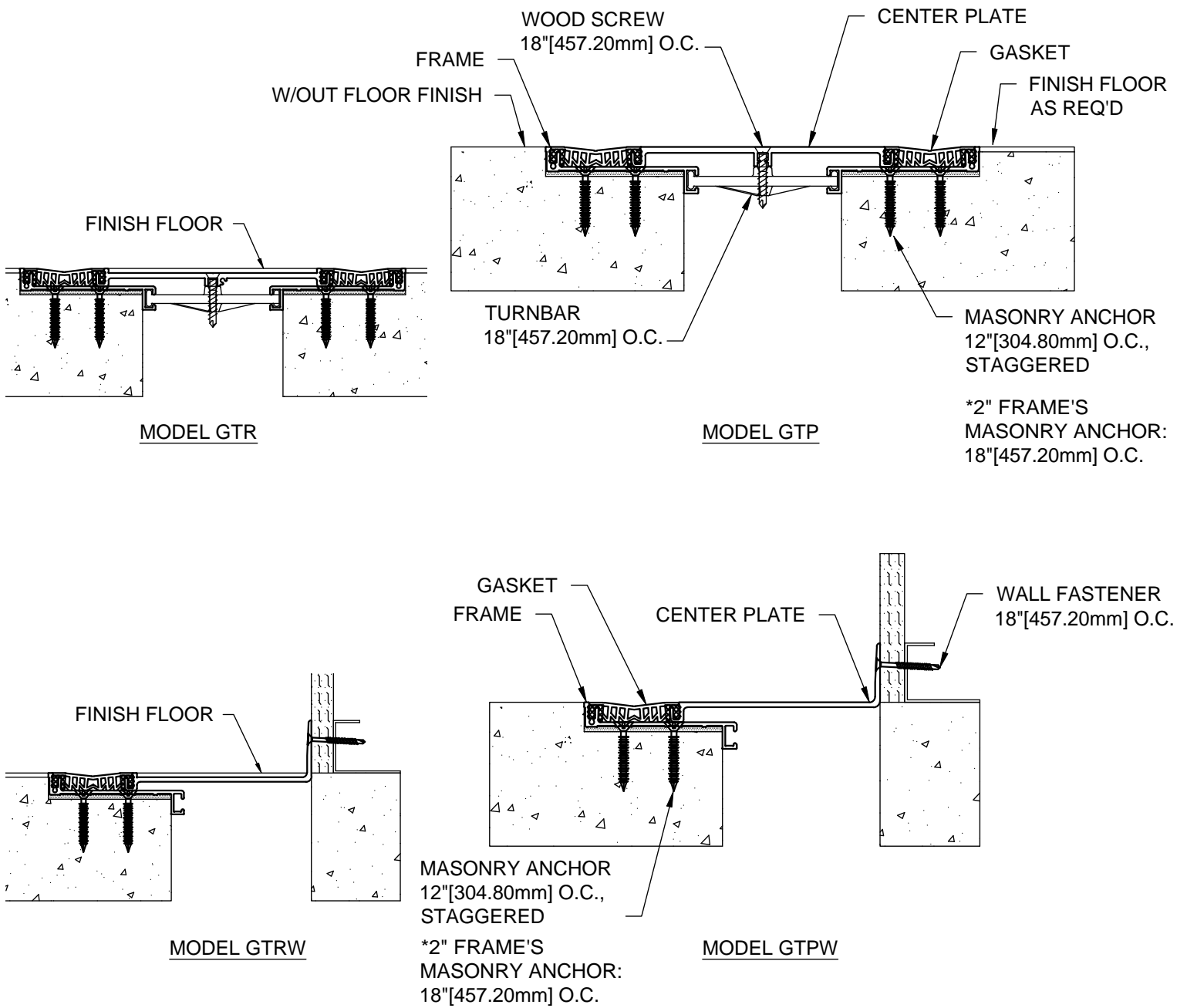

Step 7:

- 7.1) When installation of the C/S Floor Expansion Joint Cover has been completed, remove all residue and foreign matter from the area and joint cover.
- 7.2) Clean the C/S Joint Cover and adjoining surfaces with a cleaner that is adequate for surface.
- 7.3) Protect the Joint Cover until the Architect's final inspection.