

**HRW-6C HANDRAIL CANADIAN/INTERNATIONAL OFFSET**

PLEASE READ

PLEASE READ THESE INSTRUCTIONS THOROUGHLY PRIOR TO BEGINNING THE HRW-6C HANDRAIL INSTALLATION!

THIS INSTRUCTION SHEET IS INTENDED TO PROVIDE A SPECIFIC GUIDE TO FOLLOW FOR THE INSTALLATION OF HRW-6C HANDRAIL. CONTAINED WITHIN IS THE TECHNICAL INFORMATION AND INSTALLATION TECHNIQUES REQUIRED TO COMPLETE AN EFFICIENT, NEAT AND LONG-LASTING INSTALLATION.

HRW-6C HANDRAIL MUST BE INSTALLED IN ACCORDANCE WITH THESE INSTRUCTIONS! FAILURE TO FOLLOW THESE INSTRUCTIONS MAY VOID ANY PRODUCT WARRANTIES AND RESULT IN AN UNSUCCESSFUL INSTALLATION. FOR SPECIFIC QUESTIONS REGARDING THE INSTALLATION OF HRW-6C HANDRAIL PLEASE CALL THE FACTORY AT (800) 233-8493 OR IN CANADA (888) 895-8955.

INSPECT ALL MATERIALS FOR DAMAGE OR MISSING PARTS. IF YOU DISCOVER DAMAGED OR MISSING MATERIALS, IN THE USA PLEASE NOTIFY THE FACTORY AT (800) 233-8493, AND IN CANADA (888) 895-8955.

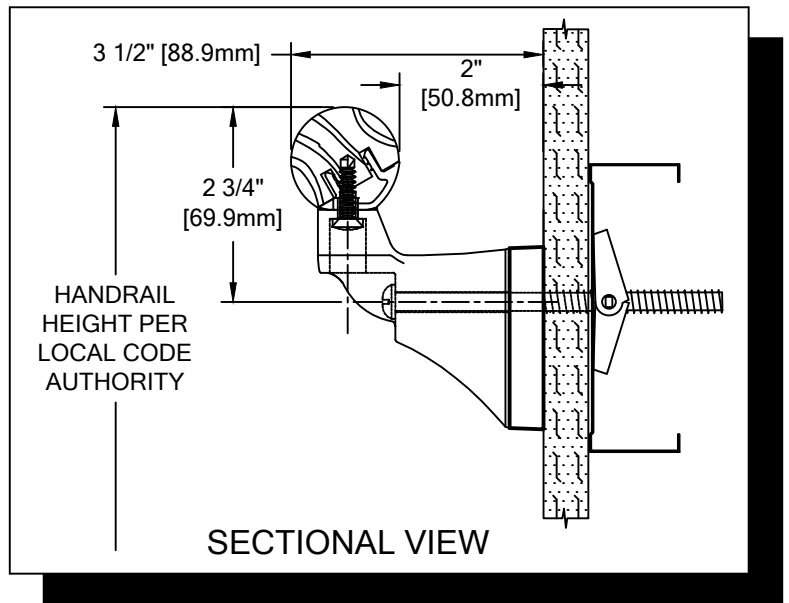

IMPORTANT NOTES

1. DUE TO WOOD BEING A NATURAL PRODUCT, COMPONENTS MAY GROW AND SHRINK AT DIFFERENT RATES. BECAUSE OF THIS, C/S HAS DESIGNED THIS HANDRAIL TO UTILIZE A BEVEL AS SHOWN IN THESE INSTRUCTIONS (SEE FIGURE 1). THIS BEVEL MUST BE APPLIED AT ALL WOOD JOINTS AND MUST MATCH FACTORY BEVEL ON END CAPS.
2. DUE TO THE NATURE OF WOOD, COMPONENT COLORS MAY VARY. SORT WOOD COMPONENTS AND MATCH PARTS BY COLOR.
3. ALL LINEAR MATERIAL TO BE SUPPLIED IN STOCK LENGTHS. WOOD IN 7'-0" TO 12'-0" VARIABLE, AND ALUMINUM IN 20'-0" LENGTHS. THIS MATERIAL IS TO BE FIELD CUT USING QUALITY EQUIPMENT TO INSURE THAT ALL CUTS ARE SQUARE. WHEN CUTTING MATERIAL SECTIONS, C/S RECOMMENDS USING AN 80-100 TOOTH CARBIDE TIPPED SAW BLADE OR EQUIVALENT, TO MINIMIZE CHIPPING AND MAINTAIN JOINT ALIGNMENT.
4. ALL DIMENSIONS ARE TYPICAL.
5. FOR DRYWALL/PLASTER WALL CONSTRUCTION, IT IS RECOMMENDED FOR FASTENERS TO BE ENGAGED INTO METAL/WOOD STUDS TO MAINTAIN MAXIMUM PULLOUT STRENGTH.
6. INSTALL OUTSIDE CORNERS FIRST.
7. INSTALL LONGEST RUN OF HANDRAIL FIRST.
8. ALUMINUM RETAINER SPLICE SHOULD NOT EXCEED 3" [76.2mm] DISTANCE FROM A BRACKET.
9. THE DISTANCE BETWEEN A WOOD SPLICE JOINT AND AN ALUMINUM RETAINER SPLICE JOINT SHOULD NOT BE LESS THAN 12" [304.8mm]
10. MATERIAL MUST REACH 65°F MIN. TO 75°F MAX. 24 HOURS PRIOR TO INSTALLATION. THIS IS ESSENTIAL TO MINIMIZE EXPANSION AND CONTRACTION OF MATERIAL.
11. MAY REQUIRE USE OF FIRE PUTTY WHEN INSTALLED ON FIRE WALL WITH TOGGLE BOLTS.
12. THIS HANDRAIL REQUIRES A MINIMUM OF 2 MOUNTING BRACKETS PER UNIT.

HRW-6C HANDRAIL CANADIAN/INTERNATIONAL OFFSET



WOOD HANDRAIL  
(24W001xxx)



ALUMINUM RETAINER  
(24A139000)



HANDRAIL MOUNTING  
BRACKET  
(24I127xxx)



FASTENER #1  
#6 X 5/8" PHILLIPS  
FLAT HEAD SMS  
(90H231002)

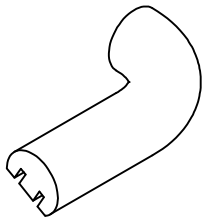

WOOD HANDRAIL END CAP  
(RIGHT-HAND 24W003xxx-SHOWN)  
(LEFT-HAND 24W004xxx)



WOOD HANDRAIL  
OUTSIDE CORNER  
(24W017xxx)



HR-6C/HRO-6C  
BRACKET EXTENSION  
(24I997xxxS)

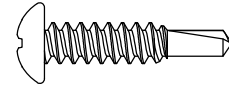

FASTENER #2  
#12-14 X 1" PPH  
#3 TEK SCREW  
(90H736002)

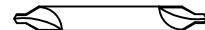

#4 X 1/2" HSS  
COUNTERSINK DRILL  
(90H035010)

WALL CONDITION	SPECIFIED FASTENER	DRILL DIAMETERS		C/S PART NUMBER
		WALL	RETAINER	
STEEL STUD/GYPSUM WALL	1/4-20 X 4" ROUND HEAD BOLT WITH TOGGLE	3/4"	N/A	90H059002
CONCRETE/CONCRETE BLOCK	#14 X 4" PH. RD. ALL-PURPOSE SCREW	7/32"	N/A	90H225002
WOOD STUD/GYPSUM WALL	#14 X 4" PH. RD. ALL-PURPOSE SCREW	7/32"	N/A	90H225002

HRW-6C HANDRAIL CANADIAN/INTERNATIONAL OFFSET

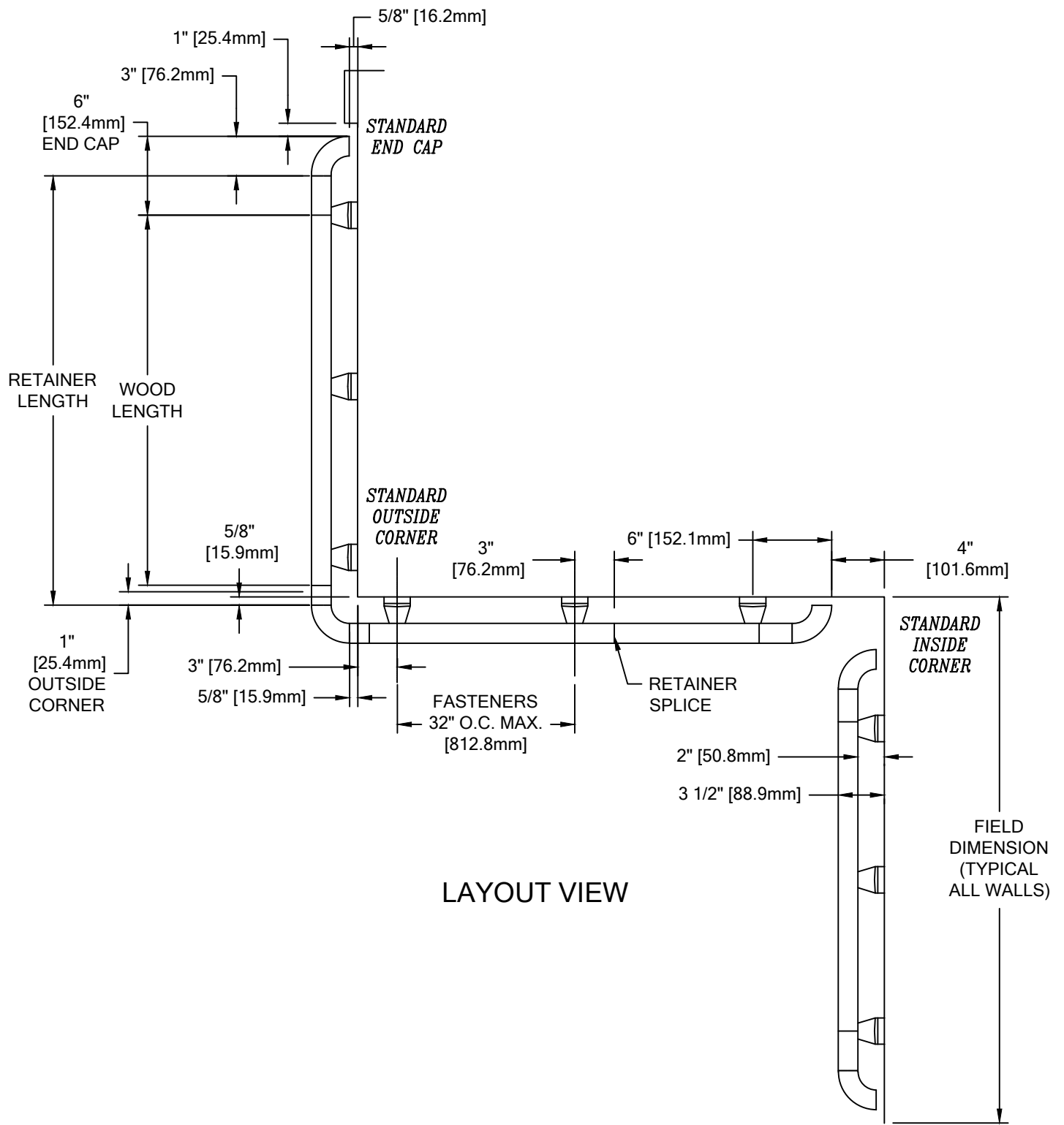

LAYOUT VIEW

**HRW-6C HANDRAIL CANADIAN/INTERNATIONAL OFFSET**

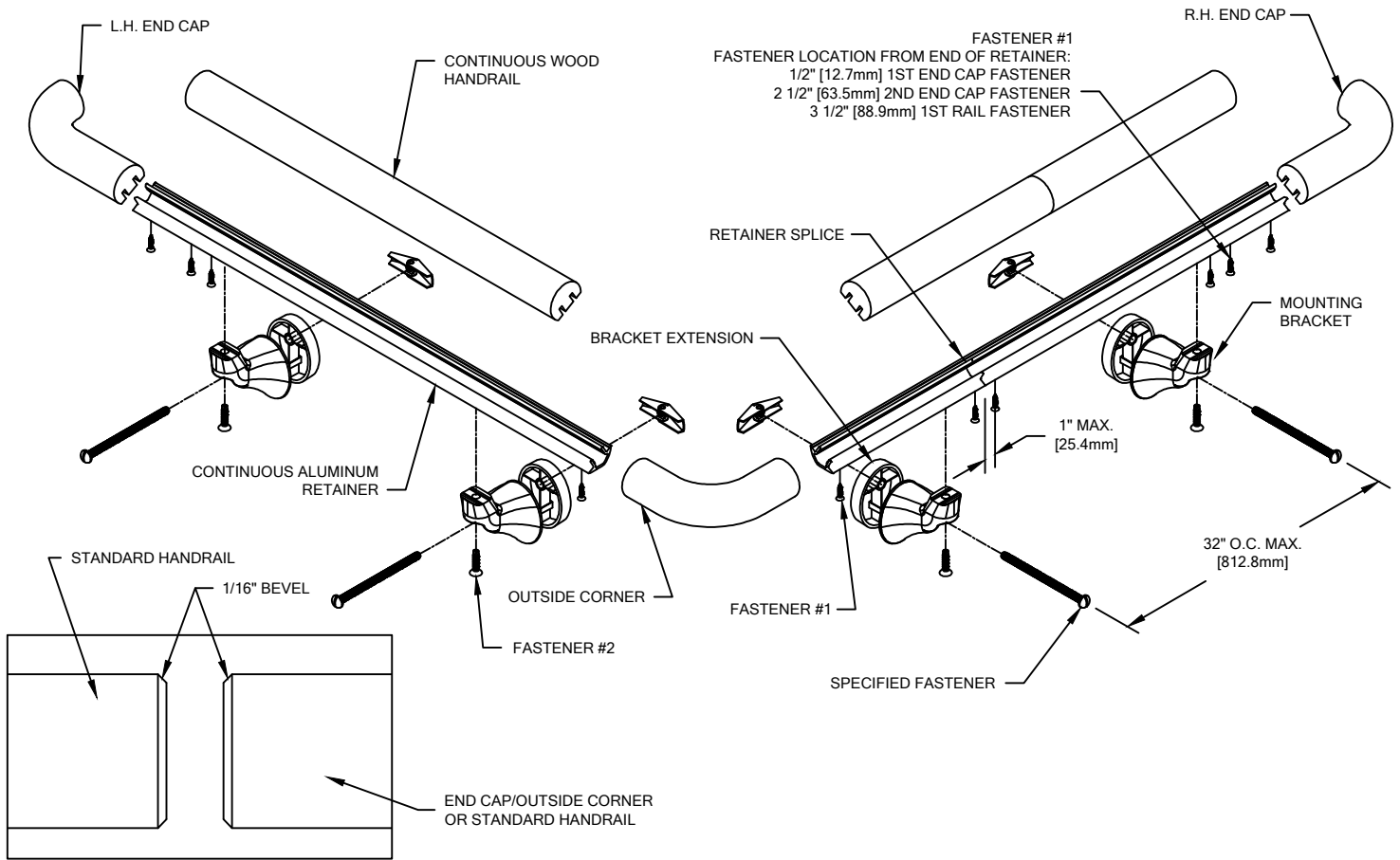

FIGURE 1

1. USING "LOCAL CODE" REQUIREMENTS, ESTABLISH HANDRAIL HEIGHT ABOVE FINISH FLOOR. DEDUCT 2-3/4" [69.9mm] AND SNAP A CHALK LINE AT THAT HEIGHT. THIS MARKS THE CENTERLINE LOCATION OF THE MOUNTING BRACKET FASTENERS.
2. DRILL CLEARANCE HOLES IN WALL SURFACE FOR MOUNTING HARDWARE. REFERENCE CHART ON PAGE 2 FOR CORRECT DRILL DIAMETERS.

**NOTE:** SEE LAYOUT VIEW TO AID IN MOUNTING BRACKET LOCATION.

3. INSTALL MOUNTING BRACKET AND BRACKET EXTENSION USING THE APPROPRIATE FASTENERS. USE A LEVEL TO ENSURE THAT THE BRACKETS WITH EXTENSIONS ARE LEVEL.
4. CUT THE CONTINUOUS ALUMINUM RETAINER TO LENGTH USING THE REQUIRED DEDUCTIONS (REFERENCE LAYOUT VIEW). FILE EDGES OF RETAINER THAT RECEIVE END CAPS TO REMOVE BURRS AND SHARP EDGES.

**NOTE:** IT IS RECOMMENDED THAT CONTINUOUS ALUMINUM RETAINER AND ACROVYN COVER BE CUT WITH AN 80-100 TOOTH CARBIDE TIPPED SAW BLADE OR EQUIVALENT.

5. MARK HANDRAIL-TO-RETAINER FASTENER LOCATIONS ALONG V-GROOVE ON BACK OF RETAINER. SEE ASSEMBLY ABOVE FOR END CAP AND SPLICE CONDITIONS. USE THE SUPPLIED COUNTERSINKING DRILL BIT TO PRE-DRILL HOLES WHERE WOOD HANDRAIL FASTENS TO RETAINER. THIS WILL ALLOW SCREW HEADS TO BE FLUSH WITH RETAINER WHEN ASSEMBLED.
6. USING THE HOLE IN THE ALUMINUM RETAINER AS A GUIDE, DRILL 3/32" DIAMETER PILOT HOLES 3/8" DEEP INTO THE WOOD END CAPS/CORNERS. ATTACH END CAPS/CORNERS TO THE RETAINER USING THE SUPPLIED #6 X 5/8" SCREWS.
7. CUT THE WOOD HANDRAIL TO LENGTH USING THE REQUIRED DEDUCTIONS (REFERENCE LAYOUT VIEW). BEVEL THE HANDRAIL EDGES SLIGHTLY WITH 150 GRIT SANDPAPER TO MATCH BEVEL ON WOOD END CAPS (SEE FIGURE 1 ABOVE). TOUCH UP SANDED EDGES WITH STAIN MARKER.
8. USING THE HOLE IN THE ALUMINUM RETAINER AS A GUIDE, DRILL 3/32" DIAMETER PILOT HOLES 3/8" DEEP IN THE WOOD HANDRAIL. ATTACH HANDRAIL TO THE RETAINER USING THE SUPPLIED #6 X 5/8" SCREWS.
9. FASTEN ASSEMBLY ONTO THE WALL BRACKETS IN SUCCESSION. INSERT #12-14 X 1" SCREW THROUGH THE UNDERSIDE OF THE BRACKET INTO THE RETAINER.