

SSM-10N CORNER GUARD

PLEASE READ

PLEASE READ THESE INSTRUCTIONS THOROUGHLY PRIOR TO BEGINNING THE SSM-10N CORNER GUARD INSTALLATION!

THIS INSTRUCTION SHEET IS INTENDED TO PROVIDE A SPECIFIC GUIDE TO FOLLOW FOR THE INSTALLATION OF THIS SSM-10N CORNER GUARD. CONTAINED WITHIN IS THE TECHNICAL INFORMATION AND INSTALLATION TECHNIQUES REQUIRED TO COMPLETE AN EFFICIENT, NEAT AND LONG-LASTING INSTALLATION.

INSPECT ALL MATERIALS FOR DAMAGE OR MISSING PARTS. IF YOU DISCOVER DAMAGED OR MISSING MATERIALS, IN THE USA PLEASE NOTIFY THE FACTORY AT (800) 233-8493, AND IN CANADA (888) 895-8955 FOR CUSTOMER SERVICE.

SSM-10N CORNER GUARD MUST BE INSTALLED IN ACCORDANCE WITH THESE INSTRUCTIONS! FAILURE TO FOLLOW THESE INSTRUCTIONS MAY VOID ANY PRODUCT WARRANTIES AND RESULT IN AN UNSUCCESSFUL INSTALLATION. FOR SPECIFIC QUESTIONS REGARDING THE INSTALLATION OF THIS SSM-10N CORNER GUARD, PLEASE CALL THE FACTORY IN THE USA AT (800) 233-8493 OR EMAIL IWPTECHSUPPORT@C-SGROUP.COM. IN CANADA CALL (888) 895-8955.

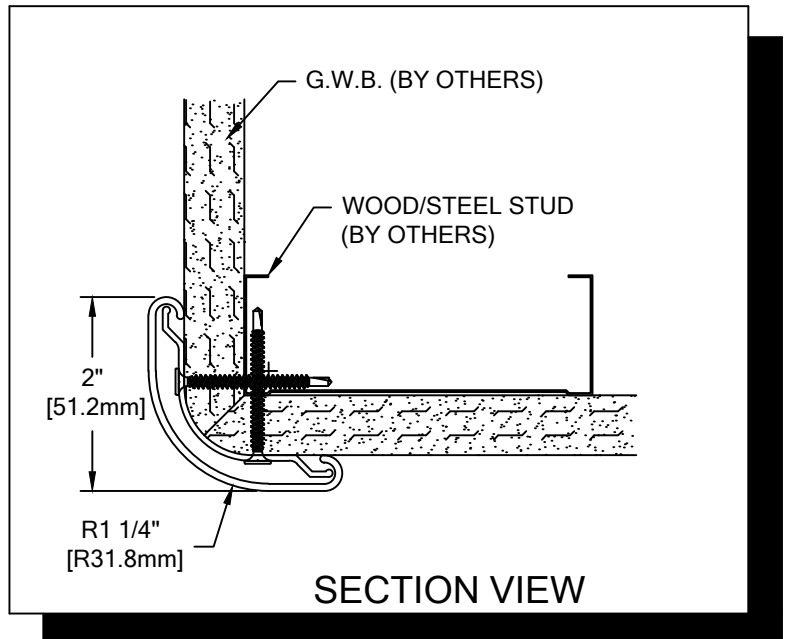

IMPORTANT NOTES

1. ALL MATERIAL TO BE SUPPLIED IN STOCK LENGTHS. ALUMINUM RETAINER AND ACROVYN COVERS IN 20'-0" LENGTHS. THIS MATERIAL IS TO BE FIELD CUT USING QUALITY EQUIPMENT TO ENSURE THAT ALL CUTS ARE SQUARE. WHEN CUTTING MATERIAL SECTIONS, C/S RECOMMENDS USING AN 80-100 TOOTH CARBIDE TIPPED SAW BLADE OR EQUIVALENT, TO MINIMIZE CHIPPING AND MAINTAIN JOINT ALIGNMENT.
2. ALL DIMENSIONS ARE TYPICAL.
3. FOR DRYWALL/PLASTER WALL CONSTRUCTION, IT IS RECOMMENDED FOR FASTENERS TO BE ENGAGED INTO METAL/WOOD STUDS TO MAINTAIN MAXIMUM PULLOUT STRENGTH.
4. MATERIAL MUST REACH 65°F MIN. TO 75°F MAX. 24 HOURS PRIOR TO INSTALLATION. THIS IS ESSENTIAL TO MINIMIZE EXPANSION AND CONTRACTION OF MATERIAL.
5. FASTENERS ARE TO BE STAGGERED BY 2" [50.8mm] TO AVOID INTERFERENCE AND SPALLING OF THE MASONRY WALL.
6. FOR MORE INFORMATION ON SSM-10N CORNER GUARDS SEE OUR WEBSITE AT www.c-sgroup.com.

SSM-10N CORNER GUARD

COMPONENTS & LAYOUT VIEW

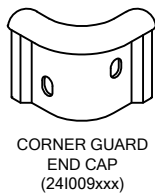

STANDARD DEDUCTIONS

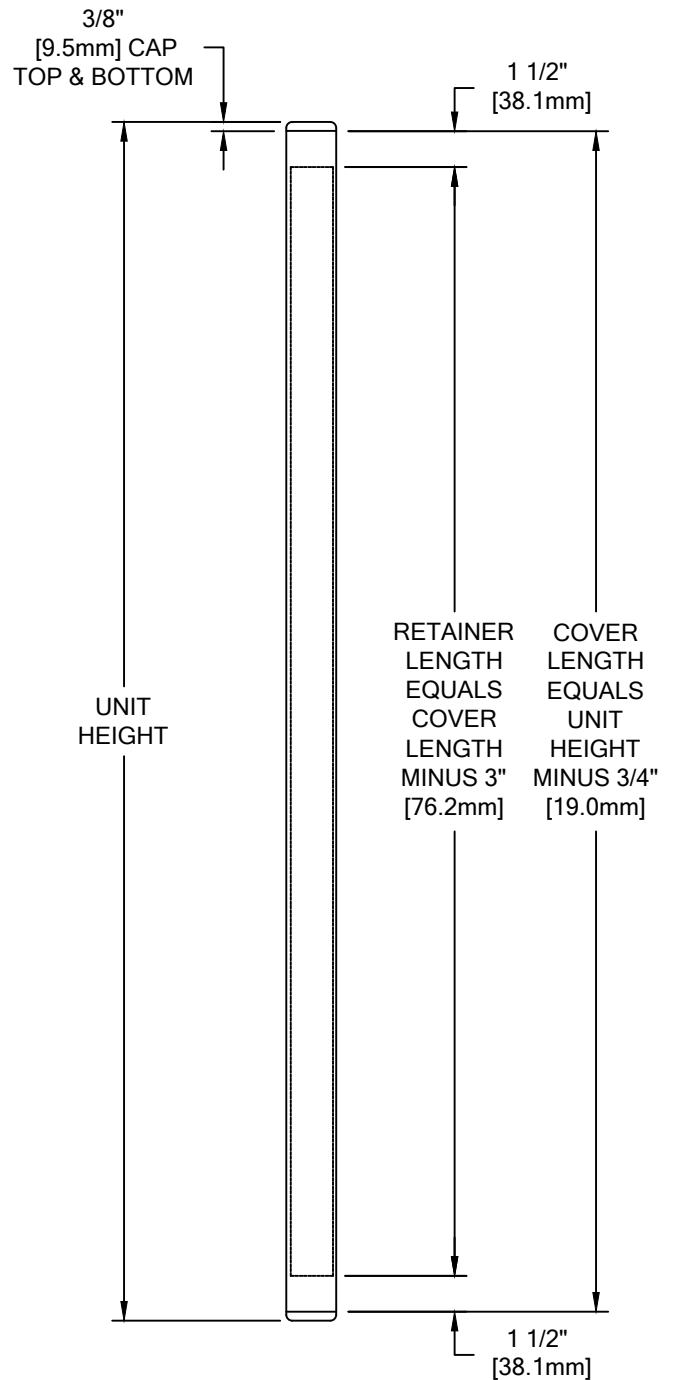

WALL CONDITION	SPECIFIED FASTENER	DRILL DIAMETERS		C/S PART NUMBER
		WALL	RETAINER	
STEEL STUD/GYPSUM WALL	#6 X 1 5/8" BUGLE HEAD SMS	N/A	7/64"	90H079002
WOOD STUD/GYPSUM WALL	#6 X 1 5/8" BUGLE HEAD SMS	N/A	7/64"	90H079002
CONCRETE/CONC. BLOCK	AF-6 PLASTIC ANCHOR #10 X 1 1/2" PHILLIPS PAN HEAD SMS	15/64"	9/32"	90H039004 90H189002

SSM-10N CORNER GUARD

TYPICAL ASSEMBLY

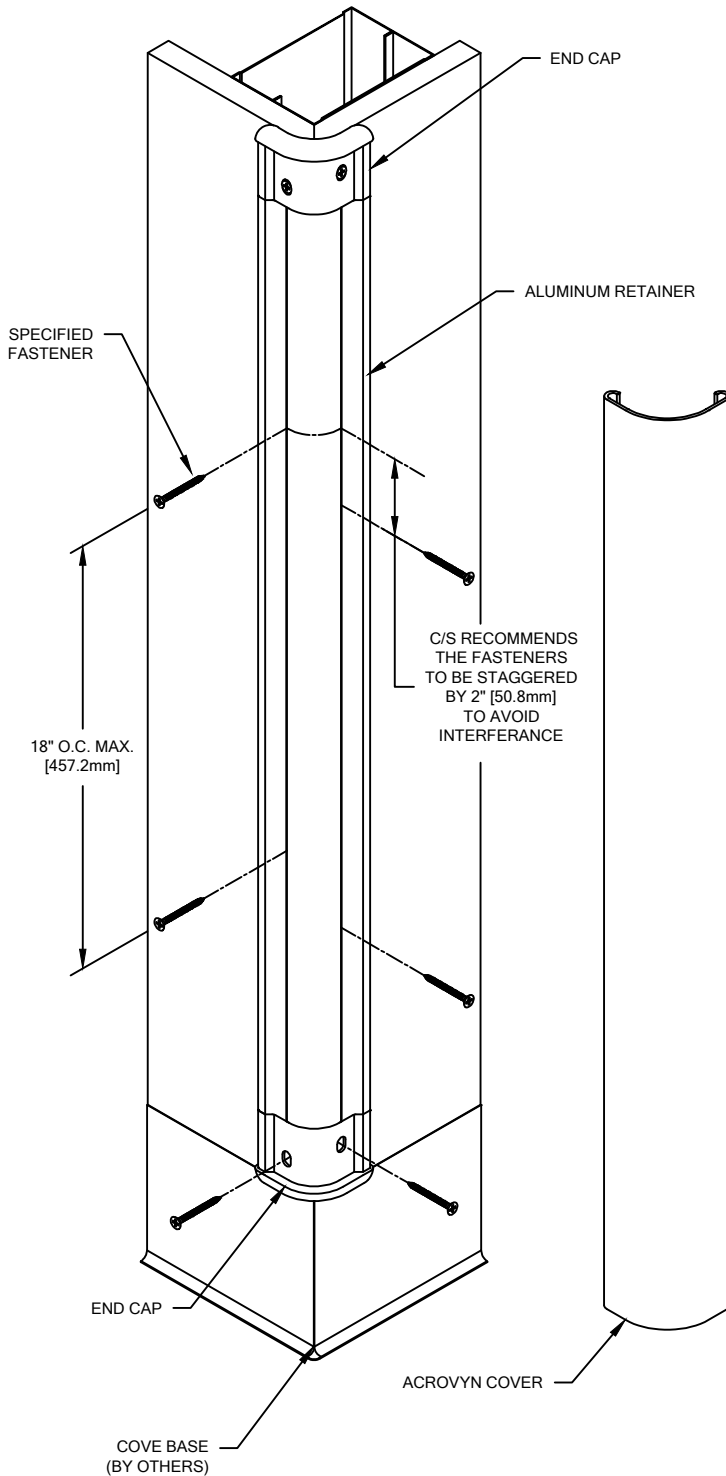

1. LOCATE AND INSTALL C/S CORNER GUARDS IN ACCORDANCE WITH ARCHITECTURAL DRAWINGS AND SPECIFICATIONS. WHEN REQUIRED, C/S SHOP DRAWINGS SHOULD BE USED IN CONJUNCTION WITH THESE DOCUMENTS.
2. LAYOUT THE WORK TO BE COMPLETED, INCLUDING COMPONENT PARTS, AT EACH LOCATION TO RECEIVE CORNER GUARDS AS INDICATED BY THE C/S SHOP DRAWINGS. SPOT CHECK THE MATERIAL FOR ANY DAMAGE INCURRED DURING SHIPPING AND/OR HANDLING AT THE JOB SITE.
3. INSTALL THE BOTTOM END CAP AGAINST THE COVE BASE OR FINISH FLOOR USING THE REQUIRED FASTENERS.
4. CUT THE CONTINUOUS ALUMINUM RETAINER TO LENGTH USING THE REQUIRED DEDUCTIONS (REFERENCE ELEVATION ON PAGE 2).

NOTE: IT IS RECOMMENDED THAT ACROVYN COVER AND ALUMINUM RETAINER BE CUT WITH AN 80-100 TOOTH CARBIDE TIPPED SAW BLADE OR EQUIVALENT.

5. ALIGN THE RETAINER WITH THE BOTTOM END CAP. MAKE SURE THAT THE RETAINER IS PLUMB WITH THE ADJACENT WALL SURFACE AND SECURE INTO POSITION USING THE SPECIFIED FASTENERS.

NOTE: DRYWALL CORNER MUST BE SHAVED DOWN FOR RETAINER TO FIT.

6. INSTALL THE TOP END CAP, IF REQUIRED, BY ALIGNING THE CAP WITH THE TOP OF THE RETAINER AND SECURING THE CAP USING THE SPECIFIED FASTENERS.
7. CUT THE ACROVYN COVER TO THE PROPER LENGTH USING THE REQUIRED DEDUCTIONS (REFERENCE STANDARD DEDUCTIONS).

NOTE: IT IS RECOMMENDED THAT THE ACROVYN COVER BE CUT SLIGHTLY LONGER (1/32" [0.8mm] UP TO 5'-0" [1.5m], 1/16" [1.6mm] OVER 5'-0" [1.5m]) THAN THE MEASURED DISTANCE. THIS ADDITIONAL LENGTH WILL PROVIDE FOR A TIGHTER COVER-TO-END CAP FIT.

8. FINISH THE INSTALLATION BY SNAPPING THE ACROVYN COVER ONTO THE RETAINER.

10/03/14